

# AFT Impulse™ Allows Space Launch System Expansion with Minimal Environmental Impact

CASE STUDY

## Sound Suppression System

Aerospace Industry



## Reynolds, Smith and Hills Merritt Island, Florida, USA Platinum Pipe Award Winner - Operational Benefits and Sustainability

RS&H has experience with launch pad water systems having designed the Ignition Over Pressure and Sound Suppression systems at Kennedy Space Center's Pad 39A & 39B in Florida (the two former Apollo and Space Shuttle launch pads), as well as the pad water system at NASA's Wallops Flight Facility in Virginia (on the east coast of the USA). This case study is a representation of an actual space launch facility; however, the information and data has been modified to avoid proprietary concerns.

William Allred, EI and Joseph Deitz, PE were asked to modify a real Space Launch Complex (or SLC, referred to here as SLC-9) Launch Water System to

The existing SLC-9 was designed for a medium class single core vehicle. It is equipped with a Launch Water System that provides cryogenic abatement spray as well as sound suppression and cooling for launch pad protection. The system uses a series of pumps to meet the current flow and timing requirements.

Proposed modifications to the system include the use of a larger vehicle having 3 cores. The vehicle requires additional below deck sound suppression capability and new above deck cooling and sound suppression capability. These capabilities require an extra 160,000 gpm (36,000 m<sup>3</sup>/hr) of water be introduced to supplement the current system.

The current system uses a sound suppression deflector ring to deliver water directly into the rocket engine exhaust stream during liftoff. Proposed modifications call for two additional sound suppression deflector rings but do not affect the cryogenic abatement spray system (see Figure 1).

Existing pumps are capable of providing enough water to satisfy the additional deflector rings. However, in order to provide enough cooling and sound suppression to the pad surface and ground support equipment, a separate system was proposed to supply water from a tank pressurized to 200 psi (1379 kPa) using gaseous nitrogen. This system sprays the pad surface at 100,000 gpm (23,000 m<sup>3</sup>/hr) via four rainbirds (nozzles) just after liftoff (see Figure 2). The pressurized tank system was recommended because its small footprint does not greatly impact the environmentally sensitive location and meets all customer requirements (see Table 1).

This Case Study is a summary of the project. [Find the full report here.](#)

**"The pressurized tank system was recommended because its small footprint does not greatly impact the environmentally sensitive location..."**

accommodate a larger launch vehicle that has 2 additional liquid cores. This was to be done with minimal new infrastructure and minimal environmental impact. A Launch Water System (also known as a "deluge system") provides a large quantity of water to a launch pad during a rocket launch. Its purpose is to break up acoustic waves which can cause structural damage as well as to provide thermal protection to structures.

The software used for this project needed the capability to accurately model both the existing and modified systems including pumps, valves, and spray nozzles, as well as the transient events in the launch sequence in order to provide the required amount of water during launch. After considering several software options, Allred and Deitz chose AFT Impulse to complete their analysis.

*Reynolds, Smith & Hills (RS&H) provides fully integrated architecture, engineering, and consulting services to help clients realize their most complex facility and infrastructure projects for land, air, and space. They are consistently ranked among the nation's top 100 design firms and have worked in over 50 countries across the globe.*

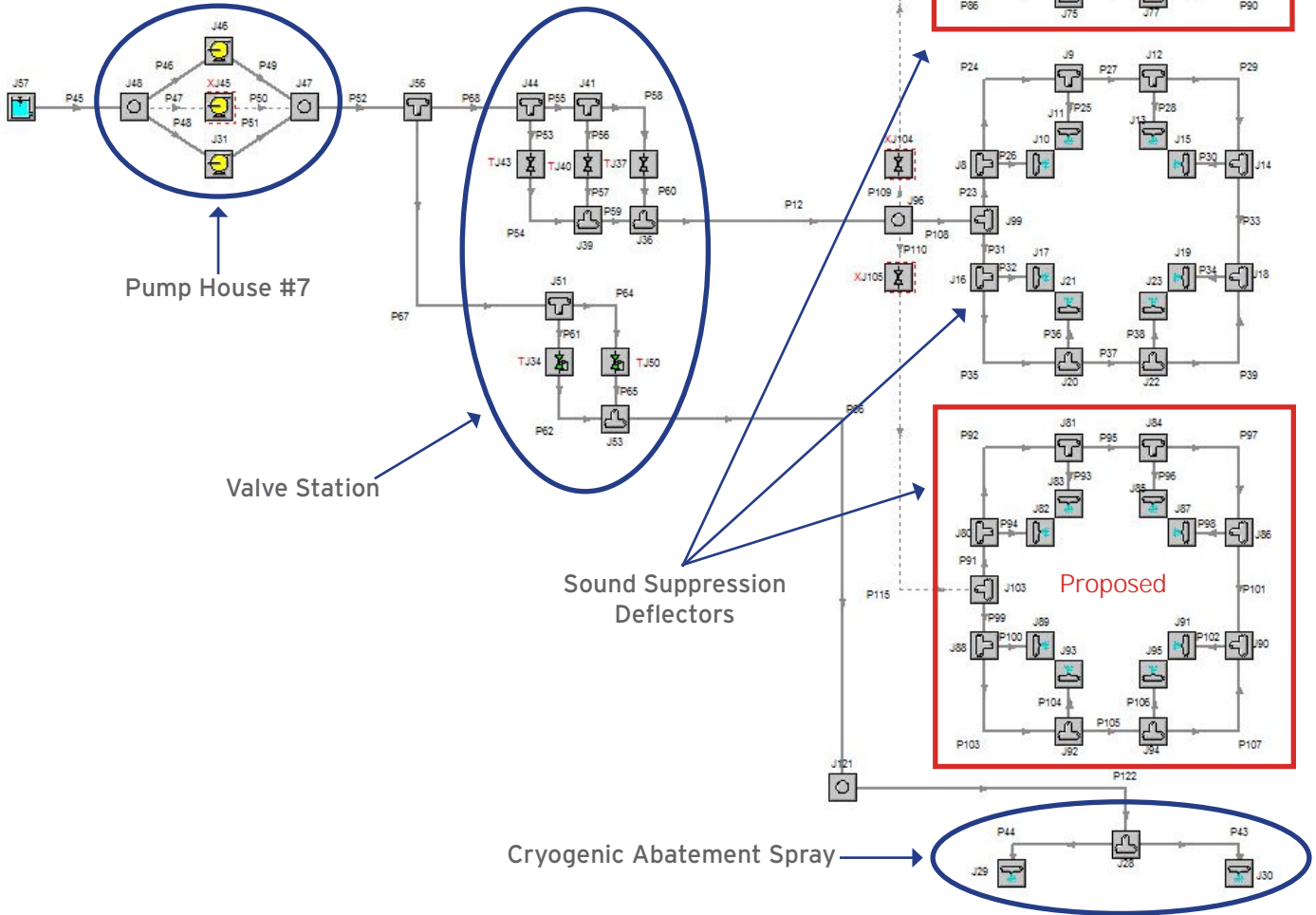
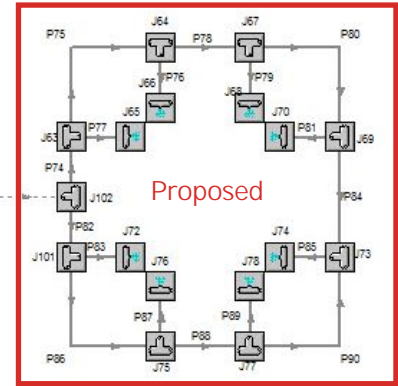
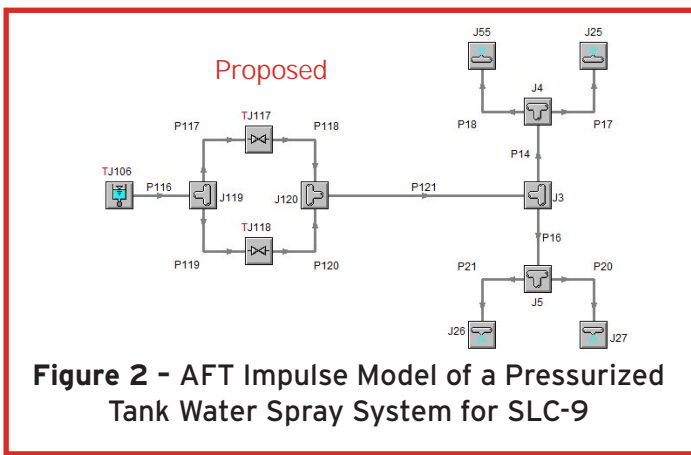

**Figure 1 - AFT Impulse Model of a Water Spray System at a Space Launch Complex (SLC-9)**

System	Current Configuration Flow Rate		Modified Configuration Flow Rate	
	Required gpm (m3/hr)	Predicted gpm (m3/hr)	Required gpm (m3/hr)	Predicted gpm (m3/hr)
Cryogenic Abatement Spray	1,400 (318)	1,417 (322)	1,400 (318)	1,490 (338)
Sound Suppression Deflectors	30,000 (6,814)	32,480 (7,377)	90,000 (20,441)	90,698 (20,600)
Sound Suppression Rainbirds	-	-	100,000 (22,713)	105,169 (23,887)

**Table 1 - Existing (Single Core Vehicle) and Modified (Triple Core Vehicle) Launch Water System Flow Rates Required and Predicted by AFT Impulse.**