

AFT Impulse™ Finds Solution to Mitigate Surge Risk in Oil Pipeline

CASE STUDY

Oil Pipeline

Oil & Gas Industry



URS

Chicago, Illinois, USA

Platinum Pipe Award Honorable Mention - Operational Benefits and Sustainability

An existing oil/gas pipeline ran from Colonial's pumping station to BP's tank in Carteret, New Jersey, USA. Both parties wanted to ensure the safety of their own systems, protecting them from high surge pressures. Steve Schade, senior process engineer at URS, used AFT Impulse to perform a study using several different mitigation scenarios.

BP had proposed a high integrity pipeline protection system using a control valve that attempted to control

first to determine the coefficient was important. This coefficient could then be entered to run the transient model.

Standard AFT Impulse capabilities such as the ability to calculate transient response and the flexibility to enter different valve coefficient vs. time values were crucial in allowing URS to consider multiple solutions that would reduce risk on both sides. The new relief valve feature was a key to the final solution.

When asked about the benefits of AFT Impulse, Schade provided the following:

"The ability to calculate transient response and the flexibility to enter different valve coefficient vs. time values were crucial in allowing URS to consider multiple solutions that would reduce risk [for both Colonial and BP]."

- "Ability to predict surge pressures for valve closing as well as for worst case scenarios."
- "Ability to analyze mitigation approaches other than the accumulator that is supplied with Impulse."
- "Ability to graph results in a format that was required by the client."

pressure, while an upstream valve closed to protect the system. Modeling with AFT Impulse proved the concept.

Additional scenarios, for worst case occurrences such as power failure, were run showing high pressures in the upstream piping. This created unacceptable risk to the Colonial pipeline.

A relief valve was added to the model and the control valve was deleted. AFT Impulse showed that the relief valve alone would protect both Colonial and BP piping (see Figure 1). The ability to run a steady state model

URS was acquired by AECOM in October, 2014. Together AECOM and URS are one of the world's premier, fully integrated infrastructure and support services firms. They design, build, finance, and operate infrastructure assets in more than 150 countries around the world—across a broad range of markets including transportation, facilities, environmental, energy, water, and government services. Their nearly 100,000 employees blend technical expertise with local knowledge to deliver innovations that have a positive physical, social, and environmental impact on our world.

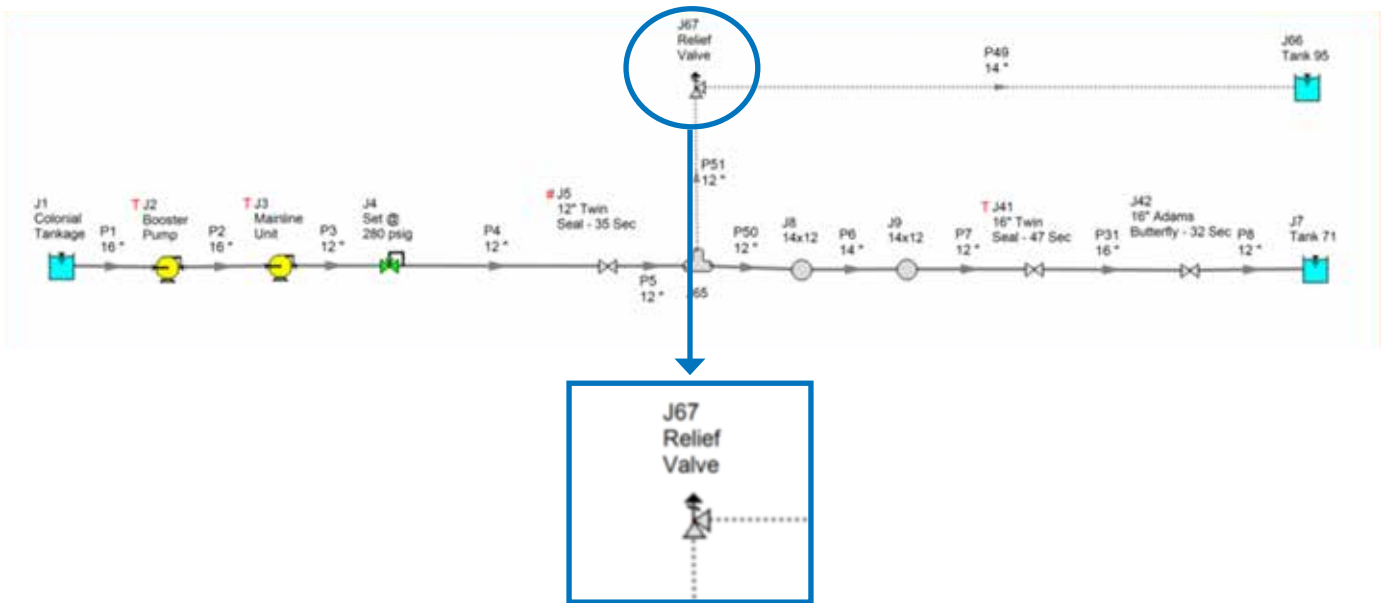

Figure 1 - AFT Impulse Model

Adding the relief valve protected both Colonial and BP piping



Colonial Pipeline Company



BP Tank Inspection - New Jersey